

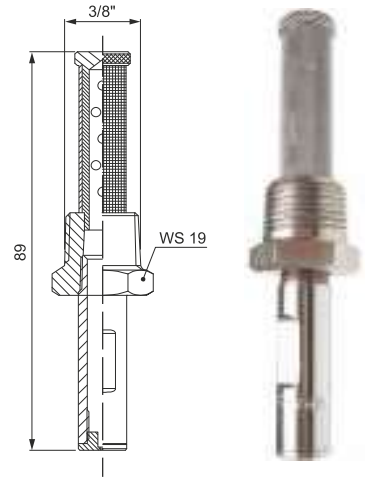

GMA SERIES PAPER WEB TRIMMERS

GMA nozzles produce a glass-rod like needle jet, ideal in paper mills to cut and trim the side of your paper web with a sharp edge, precise, clean and with no dust. They are precisely machined. Their smooth high quality ruby tip and special design produce a solid straight jet for precision trimming. A 150 mesh stainless steel filter avoids clogging. Their stainless steel body and ruby spray tip assures a long service life.

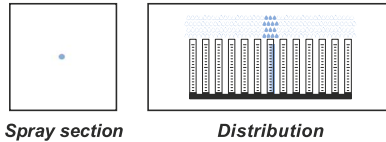

- **Thread specification:** 3/8" BSPT, 3/8" NPT
- **Filtering fineness:** 150 Mesh
- **Typical applications**
Felt and wire cleaning
Parts washing
Paper trimming



	Code	D mm
0°	GMA 0380 xxy	0.381
	GMA 0500 xxy	0.508
	GMA 0630 xxy	0.635
	GMA 0810 xxy	0.810
	GMA 0890 xxy	0.889
	GMA 0910 xxy	0.914
	GMA 1010 xxy	1.016
	GMA 1220 xxy	1.219

NEW **New code!**

GMA codes have been modified, based on the orifice diameter, measured for every nozzle. Please contact use if you need the capacity at different pressure.

PERFECT CLEANING

GMA top quality ruby tips produce a solid needle spray jet to trim paper web with a precise and sharp edge cut.

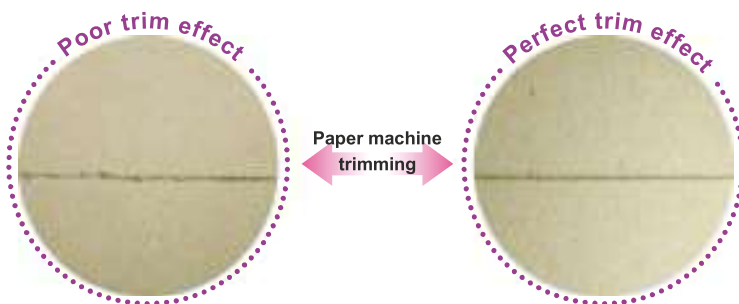

HOW TO MAKE UP THE NOZZLE CODE

EX.: GMA 0380 F30B

